

# AG1562 BEARING ASSEMBLY FOR YETTER INSTALLATION INSTRUCTIONS

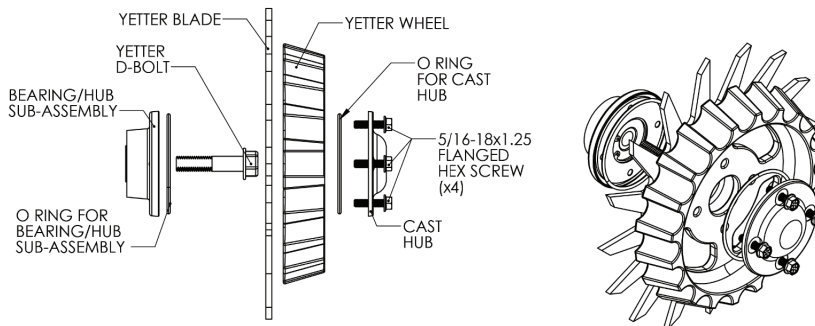

## ASSEMBLY INSTRUCTIONS

- 1) ALIGN MOUNTING HOLES ON YETTER BLADE & WHEEL
- 2) PLACE O RINGS IN GROOVES IN EACH HUB
- 3) APPLY LOCTITE TO FEMALE THREADS OF HUB/BEARING BEARING ASSEMBLY & MALE THREADS OF FLANGED HEX SCREWS (x4)
- 4) PLACE HEX SCREWS (x4) THRU HOLES ON CAST HUB
- 5) PLACE YETTER D-BOLT THRU HUB/BEARING ASSEMBLY (SLIP FIT)
- 6) ALIGN HEX SCREWS AND CAST HUB ASSEMBLY WITH THRU HOLES ON YETTER COMPONENTS AND THREADED HOLES ON HUB/BEARING SUB-ASSEMBLY
- 7) FASTEN HEX SCREWS INTO HUB/BEARING ASSEMBLY

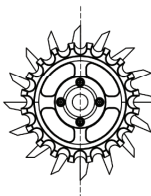
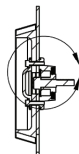

AG-1562

ANY QUESTIONS?-800-548-6633

INFO@CFCDIST.COM

WWW.CFCDIST.COM